

# CCCustomize your foam

3-Component dosing  
technology with the new  
Elastocool® iQ system

*top energy  
efficiency*

*Sustainable*

*improved  
Surface Quality*



*excellent  
insulation*

*high  
flexibility*

*fast  
demolding*

ELASTOCOOL® iQ

**■ BASF**

We create chemistry

# Ready for the new EU energy labels!

## 3-Component dosing technology with the new Elastocool® iQ system

Target scenario as part of the EU Ecodesign Directive

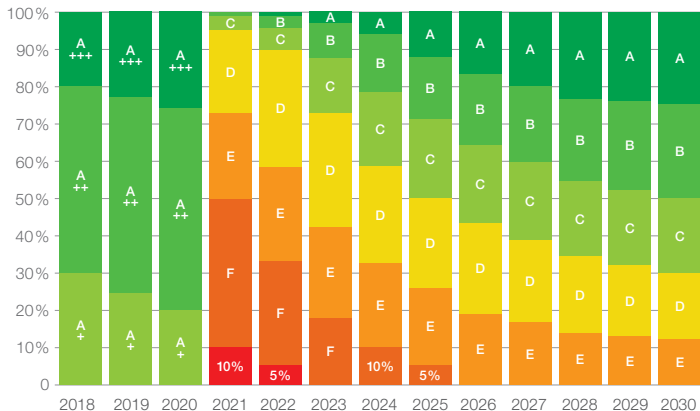

### ■ Industry need:

Novel solutions to reach the demanding EU targets

### ■ BASF solution:

Elastocool® iQ, based on 3-component dosing, offers maximum flexibility in an optimized production environment

Energy label class distribution of household refrigerating appliances

Source: <https://eur-lex.europa.eu/Document/ID:52019SC0341>

# 3-Component processing

Simple and versatile – Elastocool® iQ technology

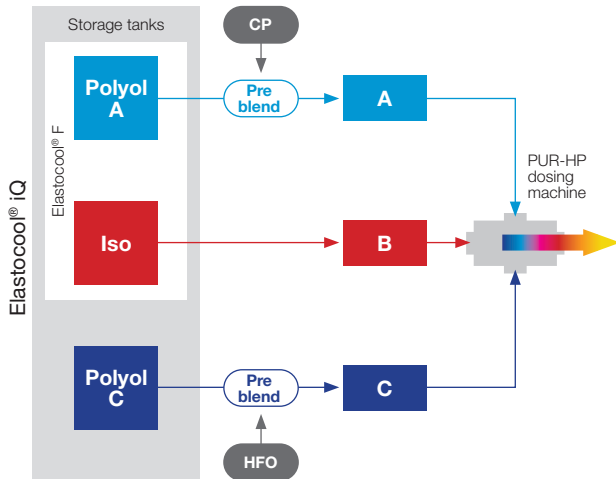

**Example of 3-Component processing:**

- **Polyol A:**  
Formulated system for CP
- **Polyol C:**  
Formulated system for HFO
- **Iso:**  
PMDI

**Customized Polyol C is further boosting thermal conductivity of Elastocool® F based on energy efficiency needs.**

# Elastocool® enables maximum flexibility in production

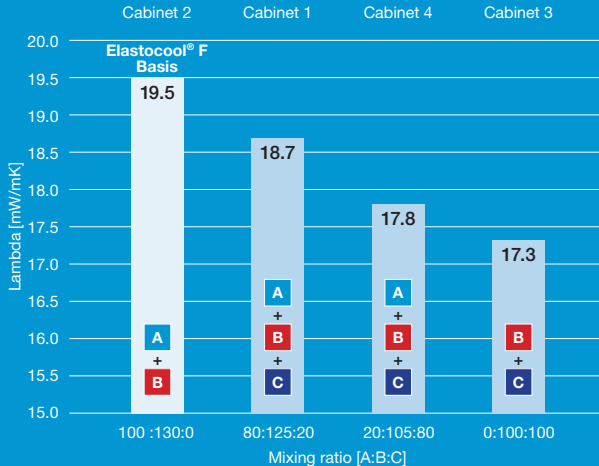

Lambda-value can be tuned simply by optimizing the mixing ratio

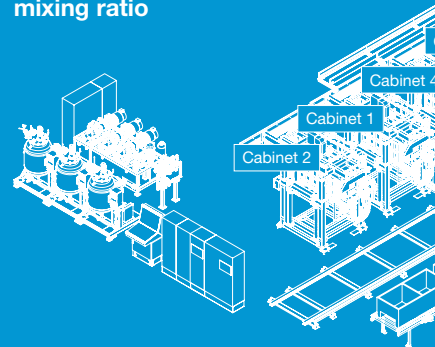

# C-component is designed to further boost the well-established Elastocool® F system

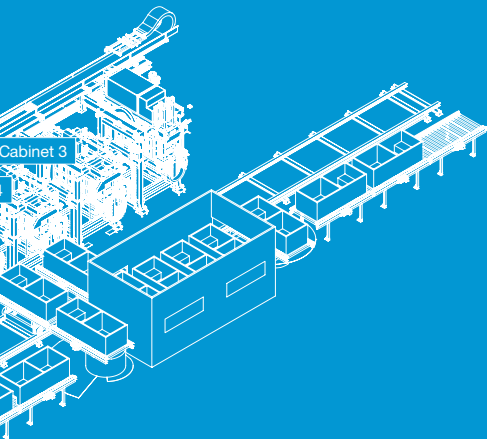

- Flexibility in production
- Adjustable lambda
- Full cost control by tailored use of HFO

## Further on-demand options for 3C processing:

- Faster demolding
- Improved surface quality
- Enhanced flowability

**Further information on Elastocool® iQ  
can be found on the internet:**

[www.elastocool.basf.com](http://www.elastocool.basf.com)

#### **Note**

The data contained in this publication are based on our current knowledge and experience. In view of the many factors that may affect processing and application of our product, these data do not relieve processors from carrying out own investigations and tests; neither do these data imply any guarantee of certain properties, nor the suitability of the product for a specific purpose. Any descriptions, drawings, photographs, data, proportions, weights etc. given herein may change without prior information and do not constitute the agreed contractual quality of the product. It is the responsibility of the recipient of our products to ensure that any proprietary rights and existing laws and legislation are observed. (September 2021)